



## Single-phase Hybrid Inverter

# Quick Installation Guide

---

HIS-3L-G3  
HIS-3.6L-G3  
HIS-4.6L-G3  
HIS-5L-G3  
HIS-6L-G3

## 1 General Declaration

- The information in this quick installation guide is subject to change due to product updates or other reasons.
- This guide cannot replace the product labels or the safety precautions in the user manual unless otherwise specified. All descriptions here are for guidance only.
- Before installations, read through the quick installation guide and the user manual to learn about the product and the precautions.
- All installations should be performed by trained and knowledgeable technicians who are familiar with local standards and safety regulations.
- Check the deliverables for correct model, complete contents, and intact appearance. Contact the manufacturer if any damage is found or any component is missing.
- Use insulating tools and wear personal protective equipment when operating the equipment to ensure personal safety. Wear anti-static gloves, clothes, and wrist strip when touching electron devices to protect the inverter from damage. The manufacturer shall not be liable for any damage caused by static electricity.
- Strictly follow the installation, operation, and configuration instructions in this guide and user manual. The manufacturer shall not be liable for equipment damage or personal injury if you do not follow the instructions.
- All cables in this article are copper cables.
- EU Declaration of Conformity











Hoymiles Power Electronics Inc. hereby declares that Hoymiles Energy Storage Inverter (model: HIS-3/3.6/4.6/5/6L-G3) is in compliance with the essential requirements and other relevant provisions of directives 2014/30/EU, 2014/35/EU, 2011/65/EU, (EU) 2015/863, and 2012/19/EU.

Hoymiles Power Electronics Inc. hereby declares that Hoymiles Data Transfer Stick (model: DTS-WL-G3) is in compliance with the essential requirements and other relevant provisions of directives 2014/53/EU, 2009/125/EC, 2011/65/EU and (EU) 2015/863.

The original EU Declaration of Conformity may be found at <https://www.hoymiles.com>.

Hoymiles Energy Storage Inverter works with Hoymiles Data Transfer Stick. Hoymiles DTS described in this document is a class B product. In a domestic environment, this product may cause radio interference, in which case the user may be required to take adequate measures.

OPERATING FREQUENCY (the maximum transmitted power): 2412 to 2472 MHz (<20 dBm).

	Caution Failure to observe any warnings may result in injury.		UKCA mark
	Danger to life due to high voltage.		Do not dispose of the inverter as household waste.
	Hot surface Burn danger due to hot surface that may exceed 60 °C.		RoHS mark
	After the inverter is turned off, wait for at least 10 minutes before opening the inverter or touching live parts.		Ukrainian certification mark
	CE mark		Observe the documentation.

## 2 Packing List

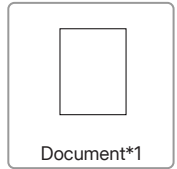
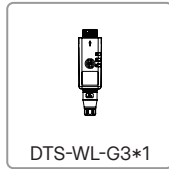
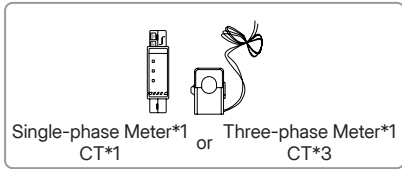
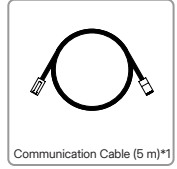
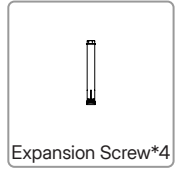
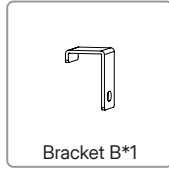
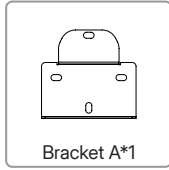
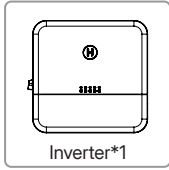

## 3 Product Appearance

Unit: mm

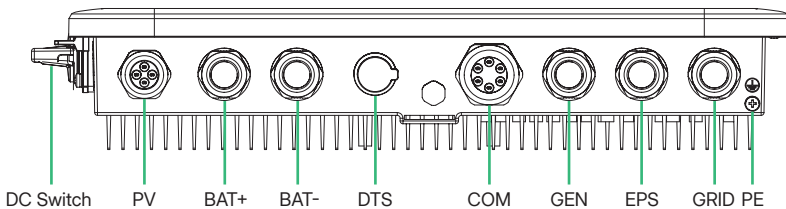
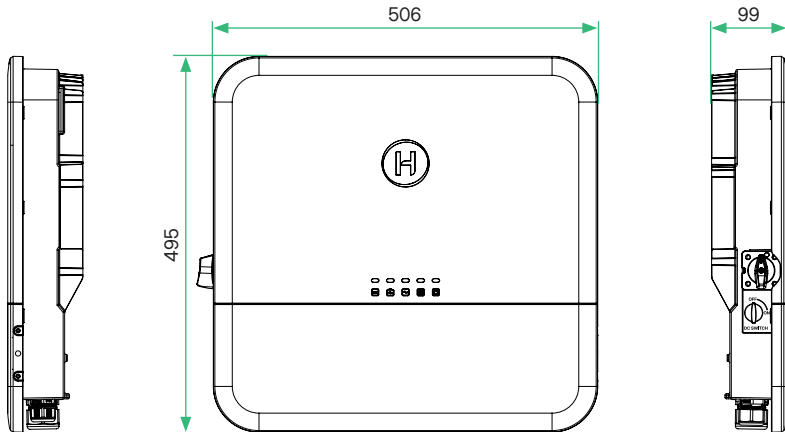

## 4 Installation Instructions

### Environmental Requirements

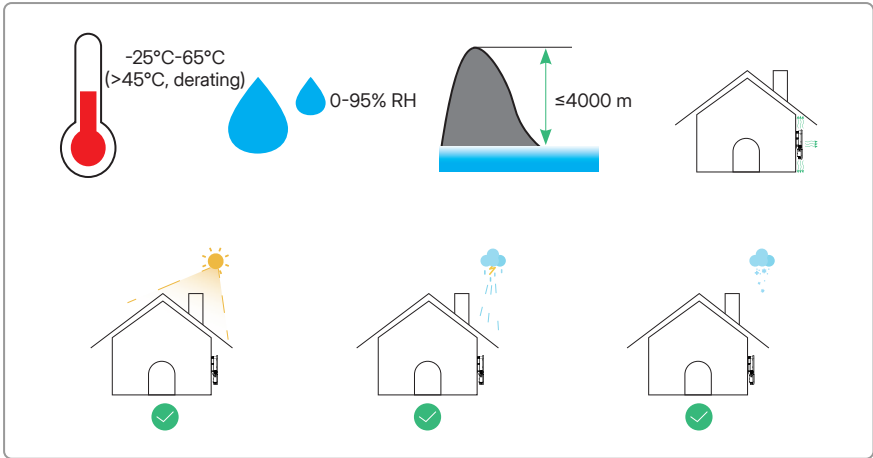

### Space Requirements

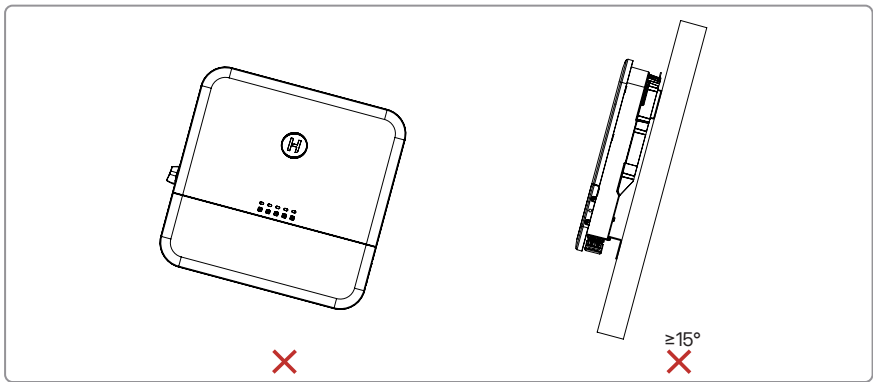
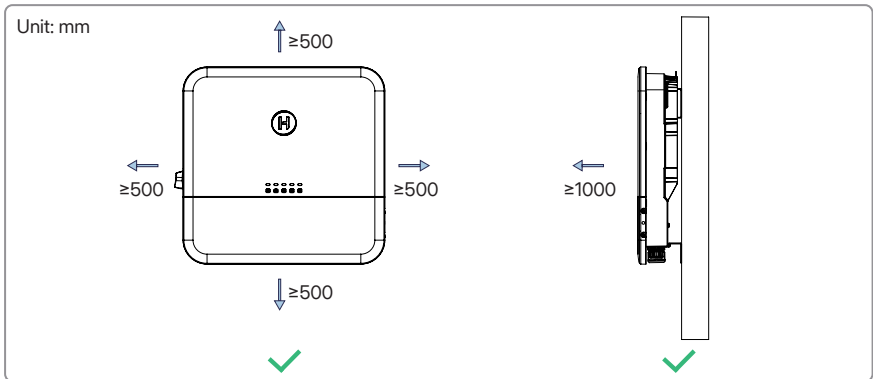

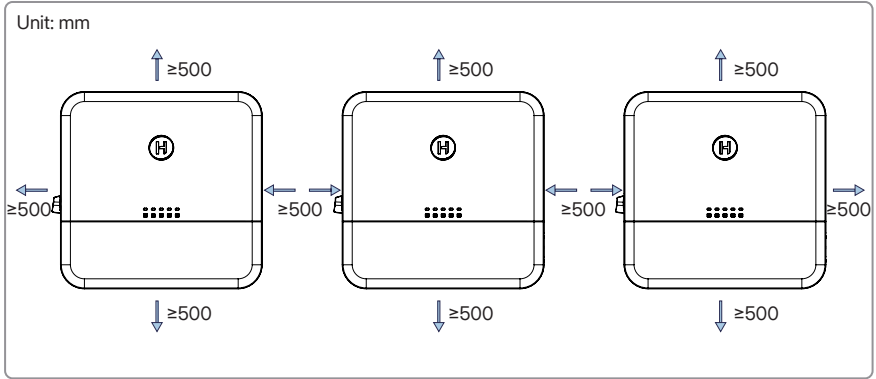

### Installation Tools

The following tools are recommended in the installation process, and other auxiliary tools can also be used if necessary.

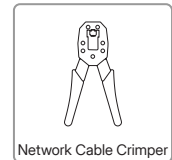
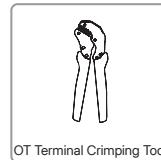
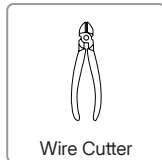
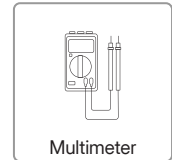
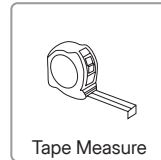
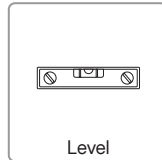
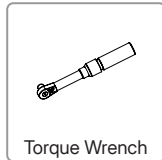
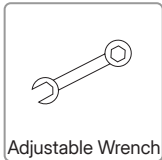
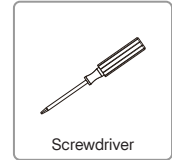
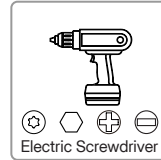
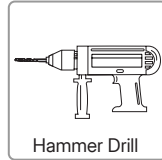
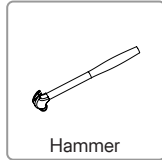

### Personal Protective Equipment



### Installation Steps

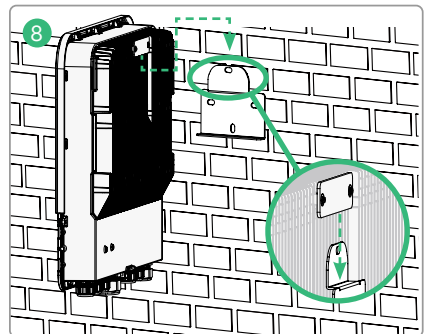
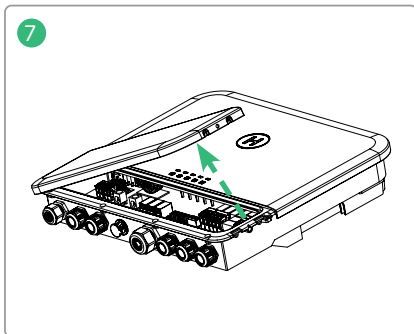
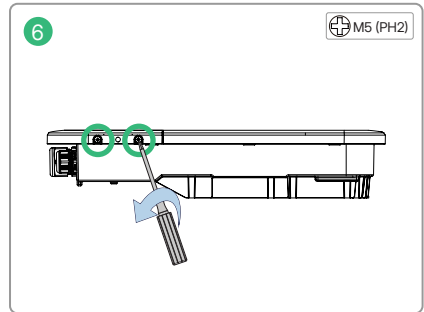
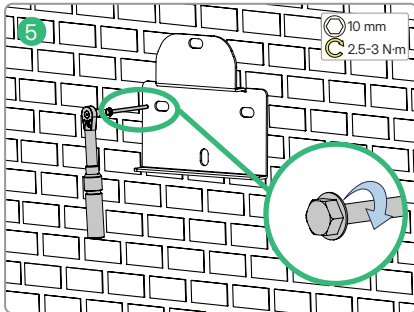
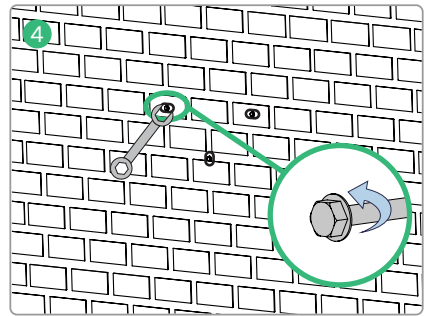
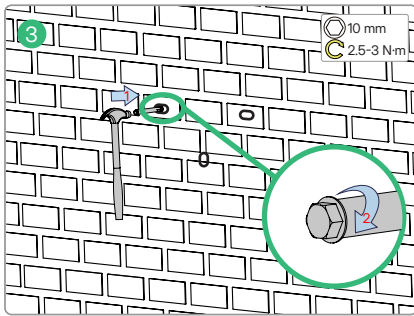
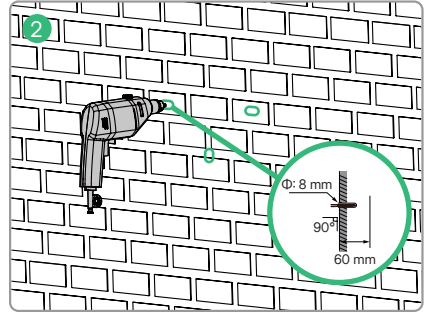
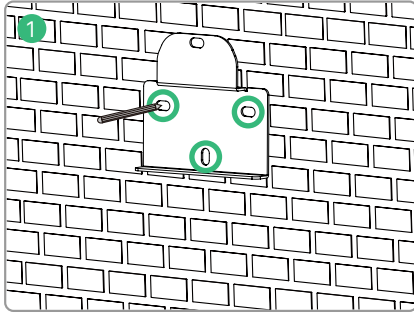

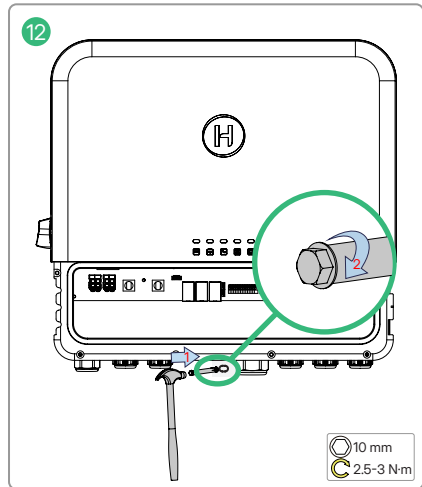
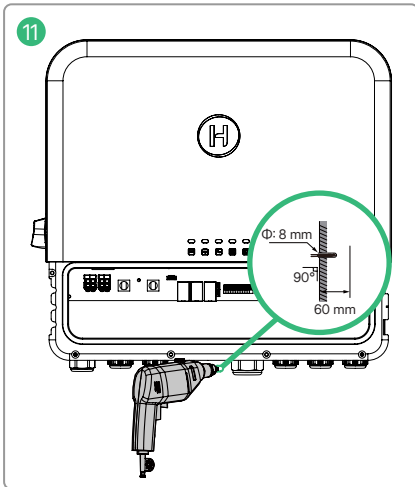
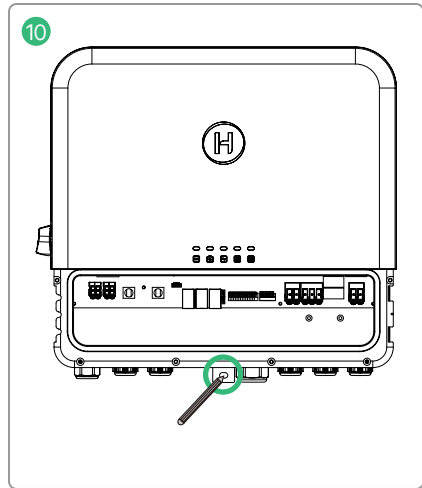
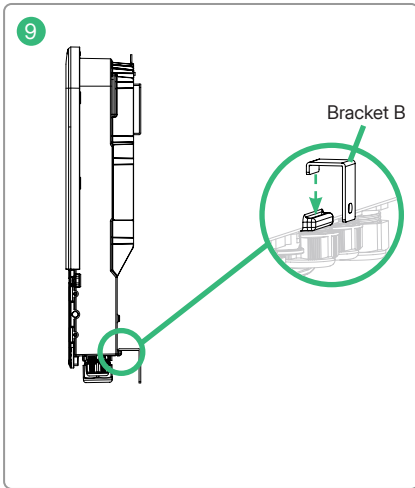

**Note:** Before proceeding with **Step 11**, remove the bracket B.

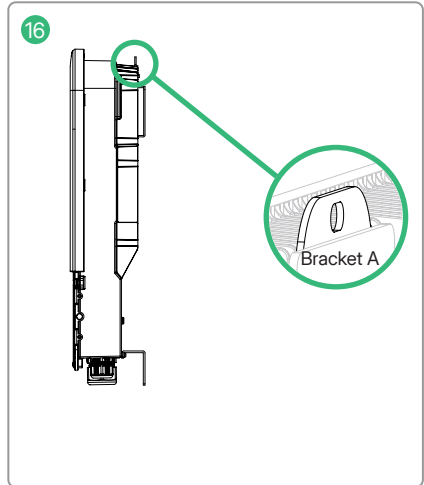
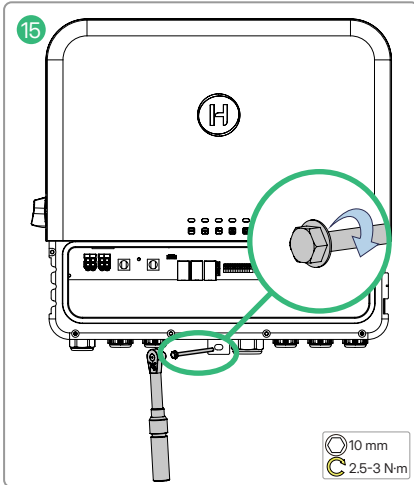
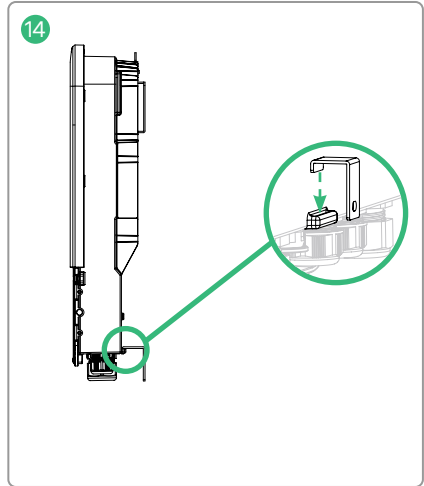
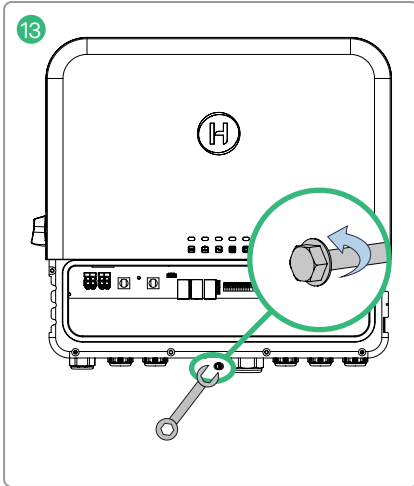

**Note:** Step 16 is optional. Hang a lock on the top of the bracket A if necessary.

## 5 Electrical Connection

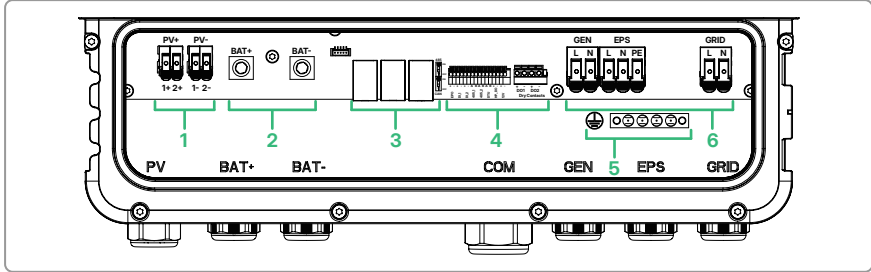

NO.	Description	NO.	Description
1	PV Terminals	4	Communication Terminals (COM2)
2	Battery Terminals	5	Grounding Bar
3	Communication Terminals (COM1)	6	AC Terminals

**Note:**

- The following data is the cable specification recommended by Hoymiles.
- The cables used in actual installation can be larger than the recommended specifications, but cannot be smaller than the recommended specifications. Select the appropriate cables in accordance with local laws and regulations.
- The wiring color code may vary. Please follow local laws and regulations for wiring.

### Ground Cable Connection

Cable (90°C, Copper)	Recommended Specification (mm <sup>2</sup> )					Stripping Length (mm)
	HIS-3L-G3	HIS-3.6L-G3	HIS-4.6L-G3	HIS-5L-G3	HIS-6L-G3	
Ground	2.5-4	2.5-4	2.5-4	2.5-4	4-6	10
Ground (Bypass)	10					10

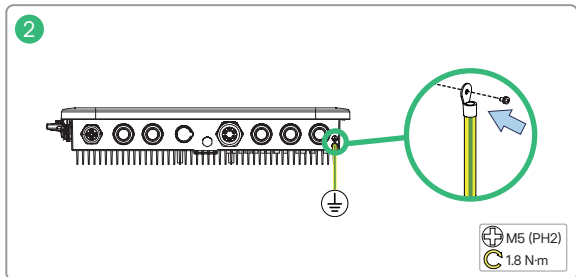
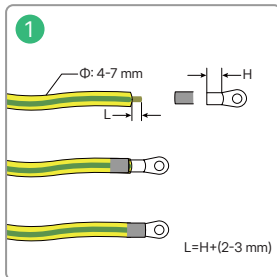

**PV Cable Connection**

Cable (90°C, Copper)	Recommended Specification (mm <sup>2</sup> )	Stripping Length (mm)
		HIS-3/3.6/4.6/5/6L-G3
PV	2.5-4	12

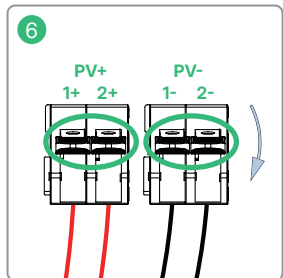
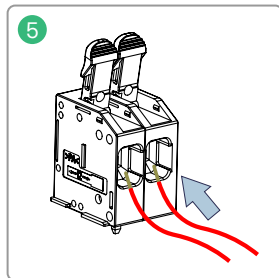
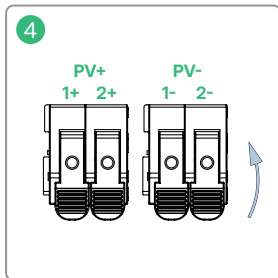
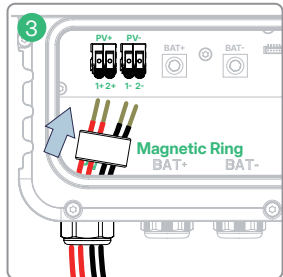
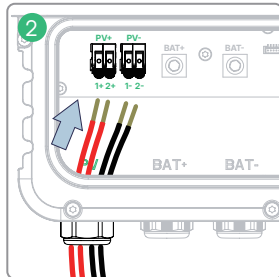
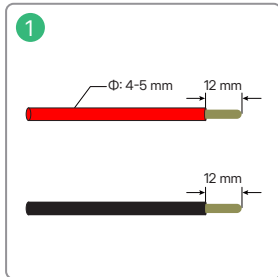
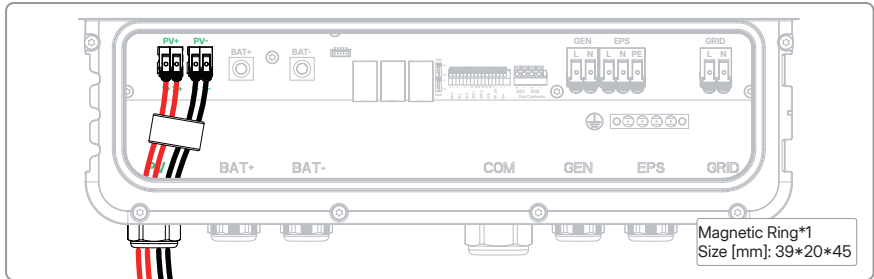

**Note:** There are rubber plugs at the bottom of the cable glands. To ensure sealing performance, remove the rubber plugs based on the actual number of cables.

### Battery Cable Connection

Cable (90°C, Copper)	Recommended Specification (mm <sup>2</sup> )					Stripping Length (mm)
	HIS-3L-G3	HIS-3.6L-G3	HIS-4.6L-G3	HIS-5L-G3	HIS-6L-G3	
Battery	16-25	16-25	25-35	25-35	35-50	18

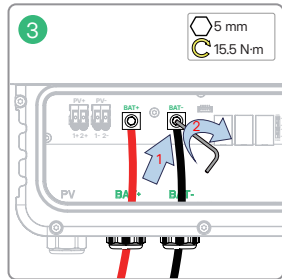
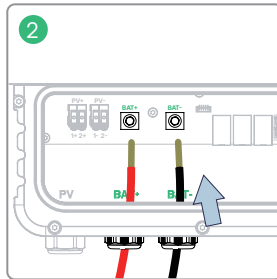
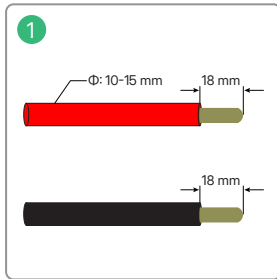
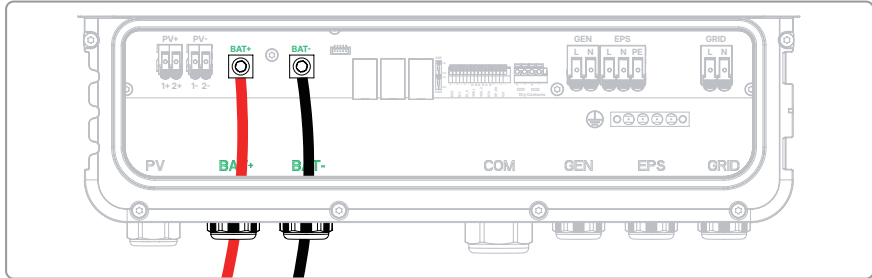

### AC Cable Connection

Cable (90°C, Copper)	Recommended Specification (mm <sup>2</sup> )					Stripping Length (mm)
	HIS-3L-G3	HIS-3.6L-G3	HIS-4.6L-G3	HIS-5L-G3	HIS-6L-G3	
GRID/EPS/GEN	2.5-4	2.5-4	2.5-4	2.5-4	4-6	18
GRID/EPS/GEN (Bypass)	10					18

Taking **HIS-6L-G3** as an example:

### Grid Connection

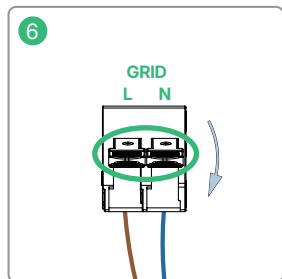
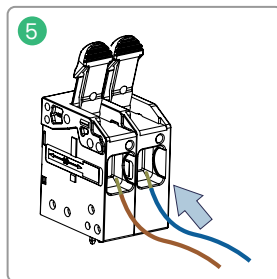
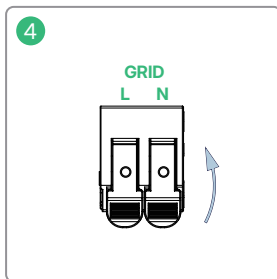
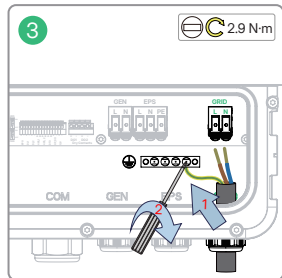
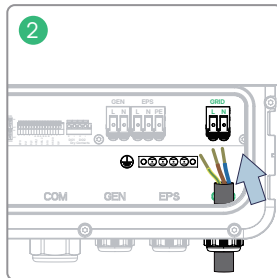
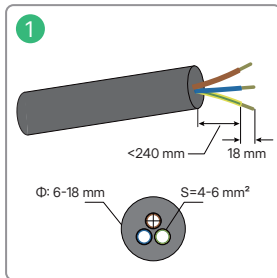
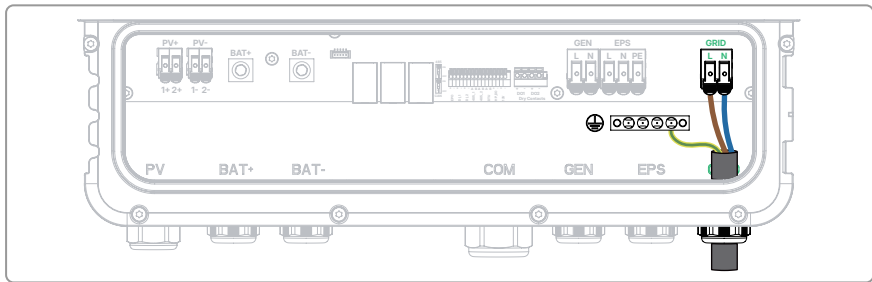

### EPS Connection

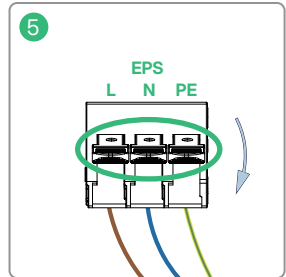
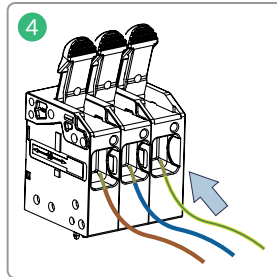
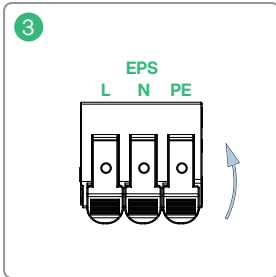
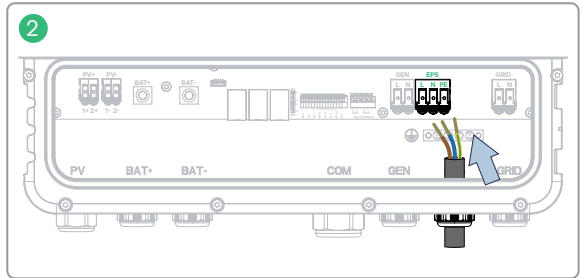
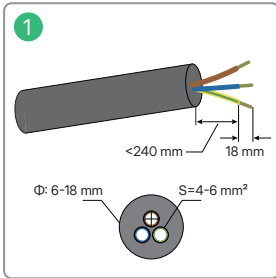
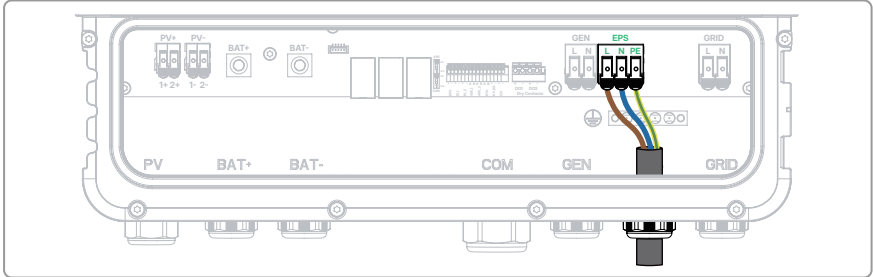



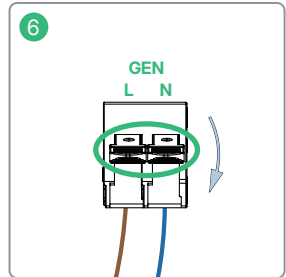
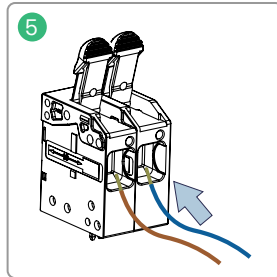
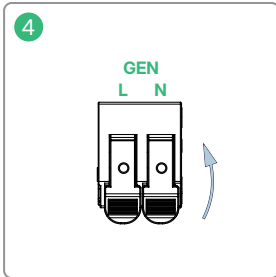
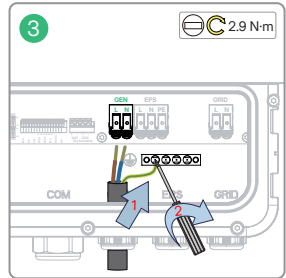
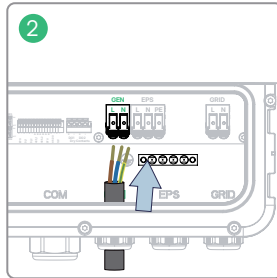
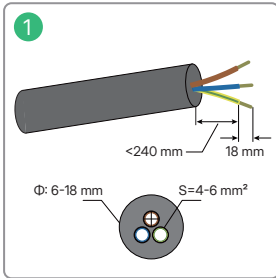
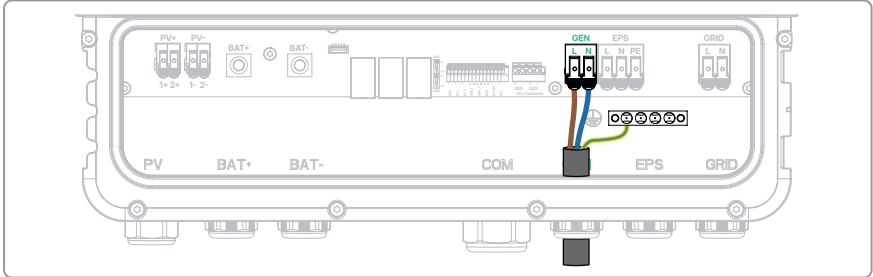



**GEN Connection**

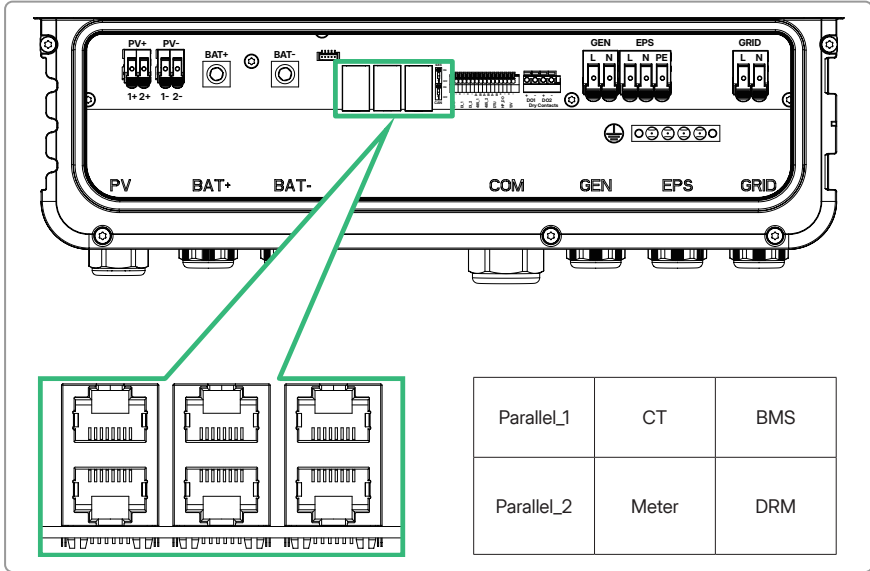

## Communication Cable Connection

### COM1 Connection



Terminal	PIN	Definition							
		1	2	3	4	5	6	7	8
Parallel		NC	GND	CANH	CANL	RXD	TXD	485B	485A
CT		IL+	NC	NC	NC	NC	NC	NC	IL-
Meter		NC	NC	NC	485A	485B	GND	NC	NC
BMS		NTC+	GND	NTC-	CANH	CANL	GND	NC	NC
DRM		DRM1/5	DRM2/6	DRM3/7	DRM4/8	REF	COM	NC	NC

Taking meter connection as an example:

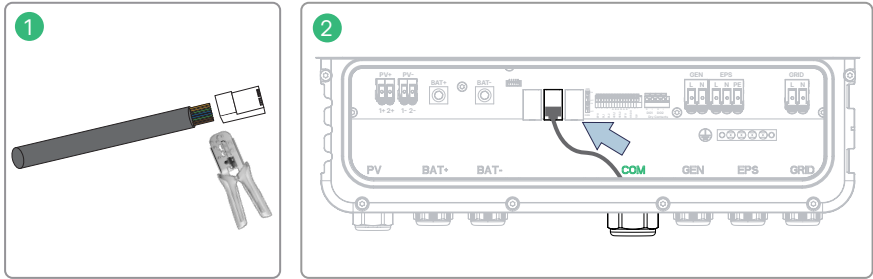

**Note:** There are rubber plugs at the bottom of the cable gland. To ensure sealing performance, remove the rubber plugs based on the actual number of cables.

### Meter and CT Connection

- Step 1** Respectively connect the meter's terminals L1 and N to Grid L and N.
- Step 2** Clamp the CT to Grid L. The arrow on the surface of the CT should point to the grid.
- Step 3** Connect the CT to the meter's CT1 terminal.
- Step 4** Use a standard Ethernet cable to connect the meter's RS485 terminal and the inverter's meter terminal.

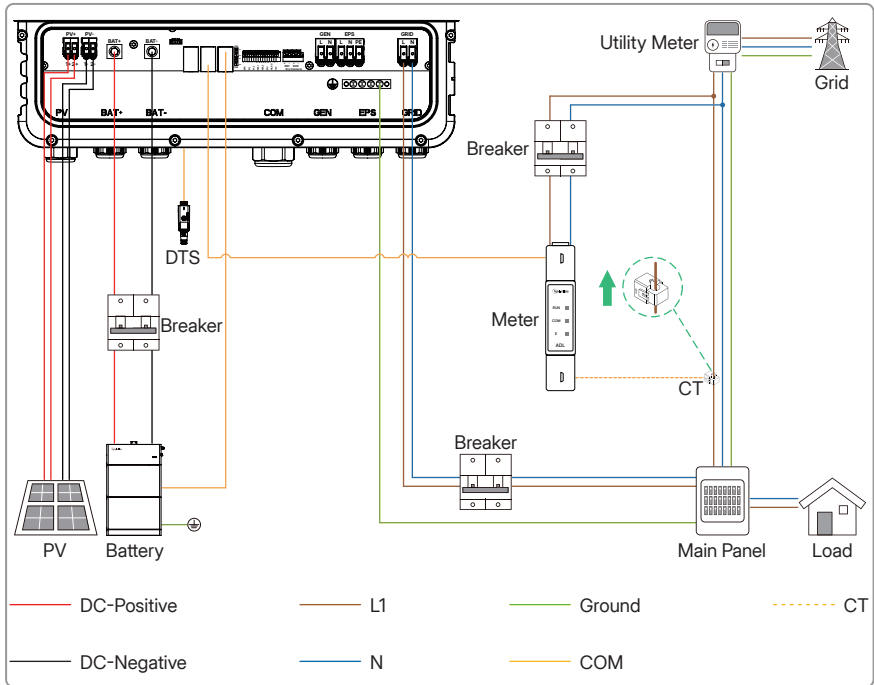

Hybrid System

- Step 1** Respectively connect the meter's terminals L1 and N to Grid L and N.
- Step 2** Clamp the grid side CT to Grid L. The arrow on the surface of the CT should point to the grid.
- Step 3** Connect the grid side CT to the meter's CT1 terminal.
- Step 4** Clamp the PV inverter side CT to L. The arrow on the surface of the CT should point to the opposite direction of the PV inverter.
- Step 5** Connect the PV inverter side CT to the meter's CT2 terminal.
- Step 6** Use a standard Ethernet cable to connect the meter's RS485 terminal and the inverter's meter terminal.

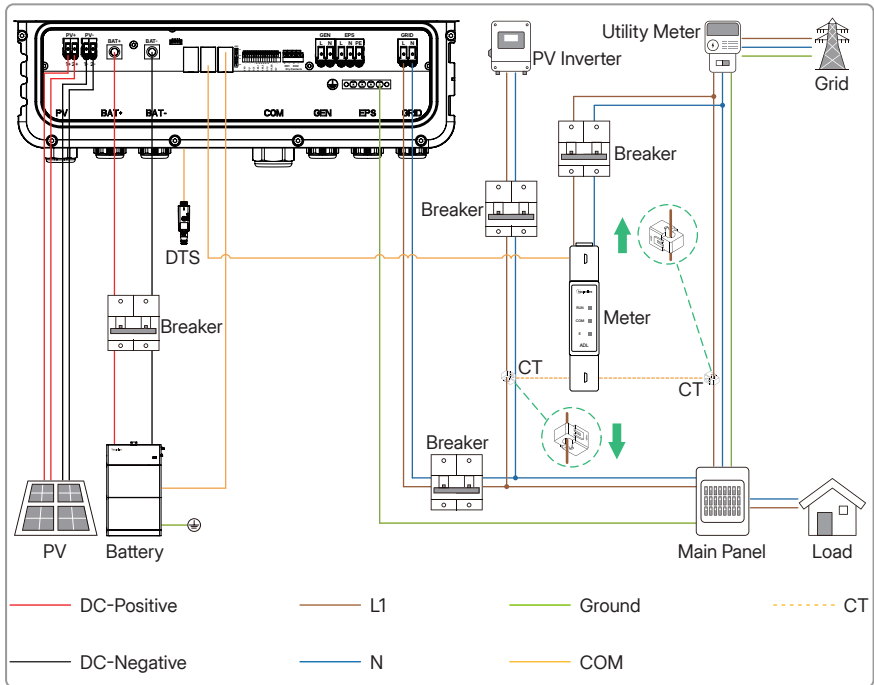

AC Coupled System

**Note:**

- The HIS-(3-6)L-G3 series inverter comes with Meter-1S-G3 (for single-phase grid) or Meter-1T-G3 (for three-phase grid) as standard.
- The PV inverter can be connected to the GEN port or the GRID port. This diagram takes the GRID port connection as an example.
- If a PV inverter is connected to the GRID port, another CT must be purchased separately from Hoymiles. The grid side CT must be connected to the meter's CT1 terminal, and the PV inverter side CT must be connected to the meter's CT2 terminal.
- If a PV inverter is connected to the GEN port, there is no need to install the PV inverter side CT.

**CT Connection**

**Step 1** Clamp the CT to Grid L. The arrow on the surface of the CT should point to the grid.

**Step 2** Connect the CT to the inverter's CT terminal.

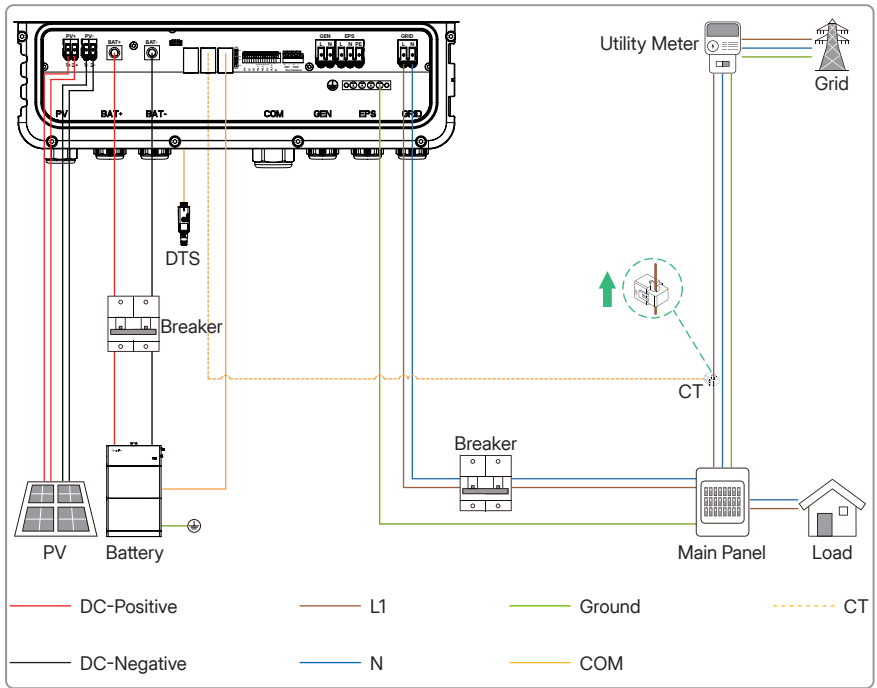

**COM2 Connection**

Cable (90°C, Copper)	Recommended Specification (mm <sup>2</sup> )	Stripping Length (mm)
		HIS-3/3.6/4.6/5/6L-G3
COM2	0.5-0.8	11

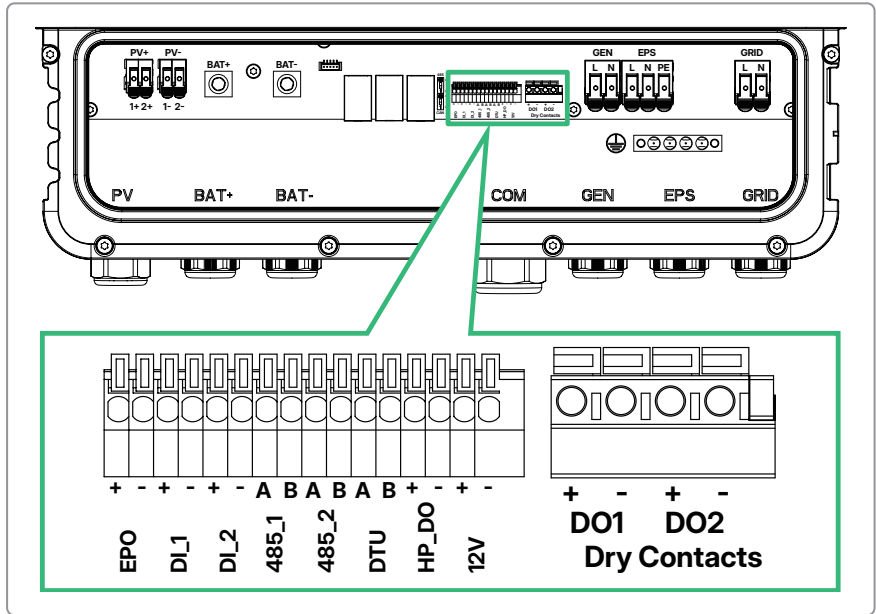

Label	Definition
EPO	For external Emergency Power Off switch.
DI <sub>1</sub> (IN+, IN-)	Reserved dry contact input.
DI <sub>2</sub> (IN+, IN-)	Dry contact input of external bypass contactor.
485 <sub>1</sub>	For the EV charger control.
485 <sub>2</sub>	For the third-party control and VPP operation.
DTU	For DTU communication.
HP_DO	For SG Ready heat pump control.
12V	(Optional) For SG Ready heat pump control.
DO1 (NO1, COM1)	Dry contact output. The DO1 can be set to one of the functions as follows: Earth Fault Alarm, Load Control, and Generator Control.
DO2 (NO2, COM2)	Dry contact output. The DO2 will control the bypass contactor under certain logic.

Taking DO1 connection as an example:

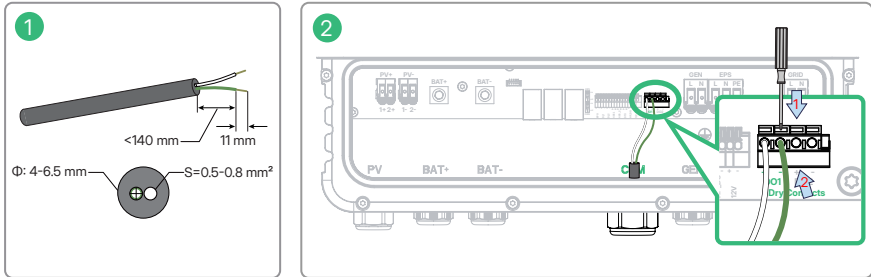

**Note:** There are rubber plugs at the bottom of the cable gland. To ensure sealing performance, remove the rubber plugs based on the actual number of cables.

### Installing the Wiring Box Cover

**Step 1&2** Put back the wiring box cover.

**Step 3** Press the wiring box cover to align the screw holes, and tighten the screws.

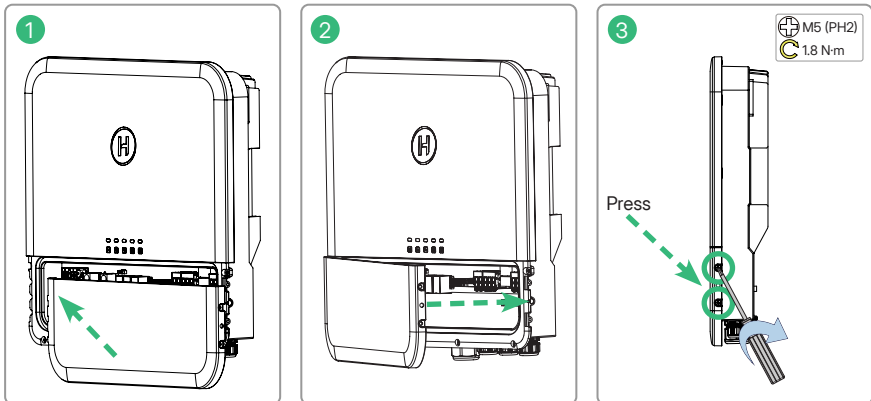

### Installing the Data Transfer Stick (DTS)

DTS-WL-G3 (Wi-Fi Mode)

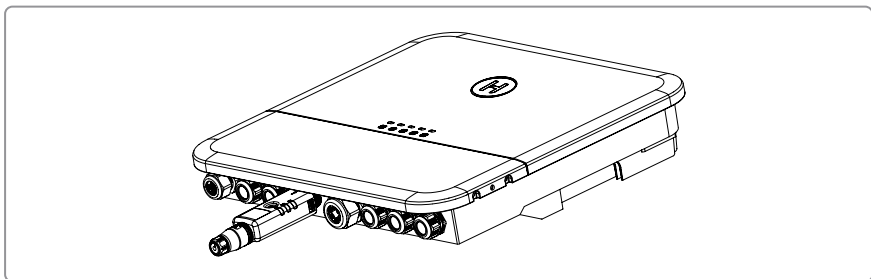

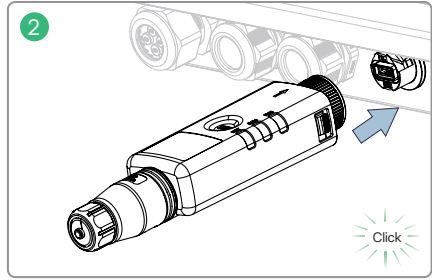
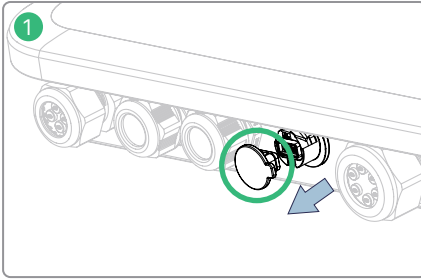

**DTS-WL-G3 (LAN Mode)**

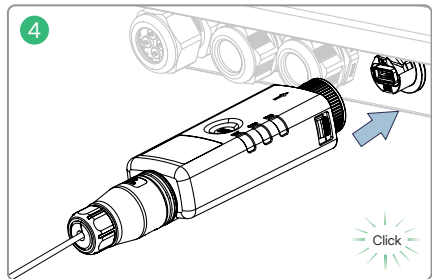
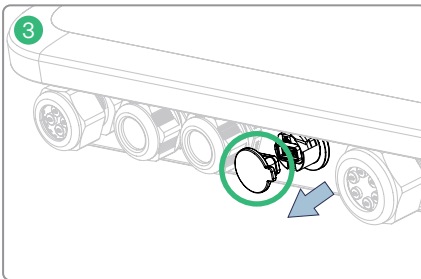
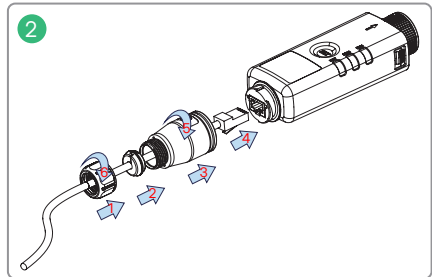
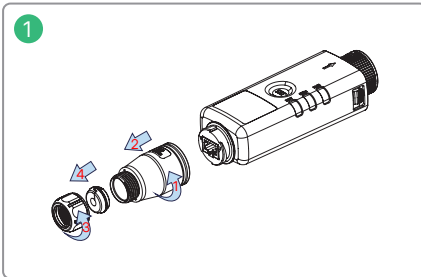
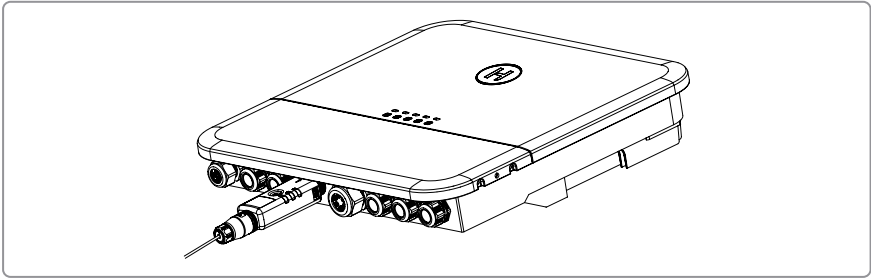





















## 6 System Power-on

**Step 1** If the inverter is connected to the battery, turn on the battery power switch and DC breaker.

**Step 2** Turn on the AC breaker between the inverter and the grid.

**Step 3** Rotate the DC switch to "ON" if the inverter is connected to the PV strings.

**Step 4** Check whether the inverter is operating properly through the inverter indicator status.

Indicator		Status		Explanation
	PV		Solid blue	Normal
			Off	No PV Power
	Battery		Solid blue	Battery Discharging
			Flashing blue	Battery Charging
			Solid red	Battery Fault
			Off	No BMS Communication
	AC		Solid blue	On-grid Mode
			Flashing blue	Off-grid Mode
			Solid red	Grid Fault
			Off	No Grid Connection
	Meter		Solid blue	Normal
			Solid red	Communication Fault
			Off	No Meter Connection
	State		Solid blue	Normal System Operation
			Solid red	System Fault
			Off	Power Off

**Note:** When all five indicators flash blue, the inverter is being upgraded.

## 7 Commissioning via Hoymiles App





User Manual in the QR code or at  
[www.hoymiles.com/download-center.html](http://www.hoymiles.com/download-center.html)



Installation video in the QR code or at  
[www.youtube.com/@Hoymiles/videos](http://www.youtube.com/@Hoymiles/videos)



**Hoymiles Power Electronics Inc.**

Add: Floor 6, Building 5, 99 Housheng Road, Gongshu District,  
Hangzhou 310015, P. R. China

Tel: +86 571 2805 6101

Email: [service@hoymiles.com](mailto:service@hoymiles.com)  
[support@hoymiles.com](mailto:support@hoymiles.com)

[www.hoymiles.com](http://www.hoymiles.com)



AP041092